

# PPM-350B

NETWORK TESTING—OPTICAL



## The market's first BPON/EPON/GPON power meter

- New PPM-352B-EG-ER: the only power meter truly optimized for EPON and GPON architectures
- Pass/warning/fail indicators (10 threshold sets) for easy assessment of power values—anywhere on the network
- Simultaneous measurement and display of all PON signals—voice, data and video
- Filtered measurements, providing distinct power values for each signal (1310 nm, 1490 nm and 1550 nm)
- Two-port pass-through configurations\* enabling full OLT-to-ONT communication while testing.
- The most easy-to-use instrument of its kind: simply connect the fiber and read the results
- Extended-range for testing at the central office (CO) and before the splitter
- Go-anywhere versatility: enables quick, accurate testing all across the network

*\*Protected by US patent no. 7,187,861, German Utility Patent no. 20 2004 021 208.0, and subject of several pending national entries in other countries under the Patent Cooperation Treaty.*



[www.EXFO.com](http://www.EXFO.com)

Telecom Test and Measurement



# EXFO

EXPERTISE REACHING OUT

überreicht durch:

**Opternus**

Opternus GmbH Optische Spleiss- & Messtechnik

Bahnhofstr. 5  
D-22941 Bargtheide

Tel. +49(0)4532-20 44-0  
Fax +49(0)4532-20 44-25

E-Mail: [Info@Opternus.de](mailto:Info@Opternus.de) - [www.Opternus.de](http://www.Opternus.de)

Büro Süd:

Wäldenbronner Str. 2  
D-73732 Esslingen

Tel. +49(0)711-3 10 59 99-0  
Fax +49(0)711-3 10 59 99-99

# A Revolutionary Testing Tool for FTTH and FTTP Systems



The PPM-350B-EG-ER

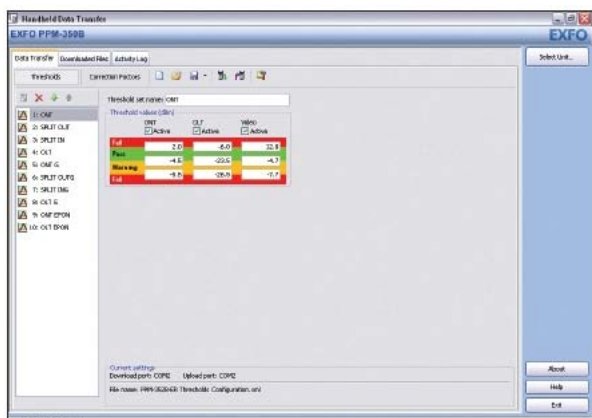

The PPM-350B's threshold configuration software interface.

The industry's first PON-specific power meter, the PPM-350B is the flagship of EXFO's line of test instruments specifically intended for FTTH and FTTP systems. The PPM-352B-EG-ER is the ideal tool for FTTH/FTTP service activation and troubleshooting.

## Service Activation Testing

Optimizing network reliability requires that all PON signals be measured all the way through service activation to ensure they meet established standards. The PPM-350B offers the features to address this need:

- Pass-through connection for ONT signal measurement and simultaneous measurement of all PON signals
- Filtered detectors for individual measurement of each wavelength
- Upstream burst detection at 1310 nm

## Troubleshooting Testing

Throughout the maintenance phase, various transmission problems—fiber cuts, damaged/dirty connectors, macrobendings, optical transmitter failure, etc.—may ultimately cause signal loss or degradation. Benefit from the PPM-350B's troubleshooting functionalities:

- Quick, on-site test and measurement of PON signals, anywhere on the network
- Fault identification and isolation

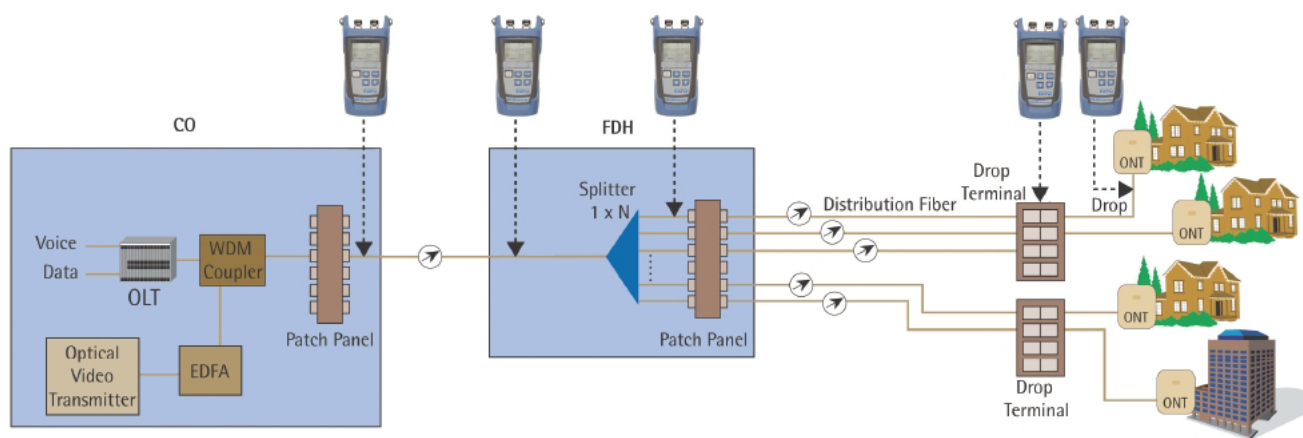

The PPM-350B is a choice solution for service activation and maintenance of all PON architectures within a network.

## Upstream Burst Detection—Not To Be Taken Lightly

Correctly measuring PON signals can be a challenging task: not only can a single fiber carry up to three signals, but the upstream signal coming from the ONT operates in burst mode, which means that it is only active during its “allowed” timeslot. This is true whether the network is based on the BPON, EPON or GPON technology. Moreover, the timeslot is shorter in higher-speed networks such as EPON and GPON. Designed with this in mind, the PPM-350B PON Power Meter delivers accurate results for burst signals.

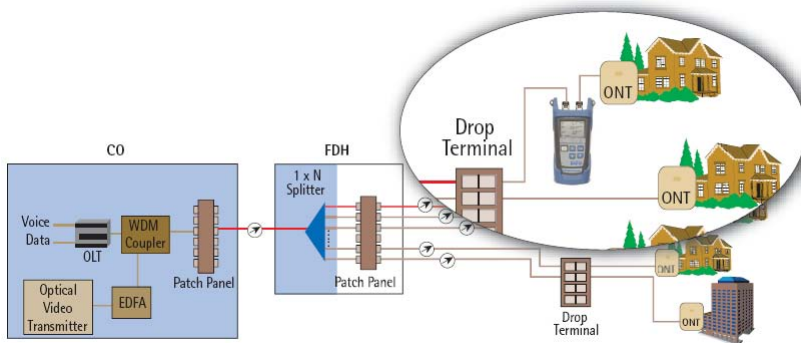

■ The PPM-350B allows for pass-through connection in any PON architecture.

## Groundbreaking Technology—Two-Port Pass-Through\*

The PPM-352B-EG-ER acts as a pass-through device, which means that it is connected between the OLT and the ONT. A small percentage of the signal is extracted for use by the power meter's detectors.

This approach enables all wavelengths to be used simultaneously. Also, since the PON equipment can keep functioning normally, the ONT continues to operate (to respond to the OLT), and therefore to transmit and have its laser on.

## Up to 10 User-Definable Threshold Sets

Depending on the location of the test and the type of equipment used, different threshold values can be required. The PPM-350B enables you to select from up to 10 threshold sets—each set consisting of three wavelengths (1310, 1490 and 1550 nm) having their own pass, warning and fail thresholds. These values can be configured via the PC-based software.

### CONFIGURATION

	PPM-352B-EG-ER
Two-port pass-through: all wavelengths; upstream measurement	X
Downstream OLT signal (1490 nm) for up to 2.5 Gbit/s	X
Downstream RF video signal (1550 nm)	X
Upstream BPON ONT signal for up to 622 Mbit/s, as per ITU 983 (A, B, C)	X
Upstream EPON and GPON ONT signal for up to 1.25 Gbit/s, as per ITU 984 and IEEE 802.3ah	X
Extended range for testing over the entire BPON, EPON or GPON architecture	X



■ The PPM-350B's display.

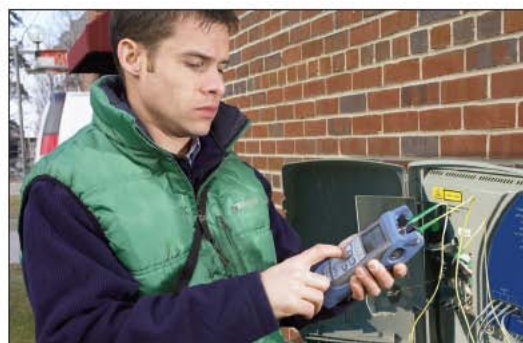

■ The PPM-352B-EG-ER used at the ONT.

\*Protected by US patent no. 7,187,861, German Utility Patent no. 20 2004 021 208.0, and subject of several pending national entries in other countries under the Patent Cooperation Treaty.

[www.EXFO.com](http://www.EXFO.com)

überreicht durch:  
**Opternus**

Opternus GmbH Optische Spleiss- & Messtechnik  
Bahnhofstr. 5  
D-22941 Bargteheide  
Tel. +49(0)4532-20 44-0  
Fax +49(0)4532-20 44-25  
E-Mail: [Info@Opternus.de](mailto:Info@Opternus.de) - [www.Opternus.de](http://www.Opternus.de)

Büro Süd:  
Wäldenbronner Str. 2  
D-73732 Esslingen  
Tel. +49(0)711-3 10 59 99-0  
Fax +49(0)711-3 10 59 99-99

Opternus GmbH  
März 2008

SPECIFICATIONS <sup>a</sup>

PPM-352B-EG-ER			
		BPON	EPON/GPON
Power measurement range – pass zone for continuous data stream (dBm)	1310 nm	10 to -40	
	1490 nm	12 to -40	
	1550 nm	25 <sup>b</sup> to -40	
Burst mode measurement capability:		CO to ONT	
Burst mode measurement range <sup>b</sup> (dBm)	1310 nm	10 to -33	10 to -29
ORL <sup>c</sup> (dB)	1550 nm		55
Pass through insertion loss <sup>b</sup> (dB)			1.5
Spectral passband (nm)	1310 nm	1260 to 1360	
	1490 nm	1480 to 1500	
	1550 nm	1539 to 1565	
Power uncertainty at calibrated wavelengths <sup>b, d</sup> (dB)		0.5	
Refresh rate of display (Hz)		2.5	
Calibrated wavelengths (nm)		1310, 1490, 1550	
Threshold sets		10 configurable threshold sets with threshold naming	
Autonomy <sup>b</sup> (hours)		> 30	
Number of ports		2	
Warranty and recommended calibration interval (year)		1	

Notes

- a. At room temperature.
- b. Typical.
- c. For APC connectors. Typically > 35 dB for UPC connectors.
- d. Around -7 dBm, CW.
- e. Same connectors for both ports.

GENERAL SPECIFICATIONS

Size (H x W x D)	185 mm x 100 mm x 55 mm	(7 1/4 in x 4 in x 2 1/8 in)
Weight	0.4 kg	(0.9 lb)
Temperature		
operating	-10 °C to 50 °C	(14 °F to 122 °F)
storage	-40 °C to 70 °C	(-40 °F to 158 °F)
Relative humidity	0 % to 95 % non-condensing	

STANDARD ACCESSORIES

User guide, three AA batteries, wrist strap, PC threshold-transfer software, RS-232 cable.

ORDERING INFORMATION

PPM-352B-EG-ER-XX

Model ■

PPM-352B-EG-ER = PON power meter, two ports, BPON, extended range EPON, GPON

Connector <sup>e</sup> ■

- EI-EUI-28 = UPC/DIN 47256
  - EI-EUI-76 = UPC/HMS-10/AG
  - EI-EUI-89 = UPC/FC narrow key
  - EI-EUI-90 = UPC/ST
  - EI-EUI-91 = UPC/SC
  - EI-EUI-95 = UPC/E-2000
  - EA-EUI-28 = APC/DIN 47256
  - EA-EUI-89 = APC/FC narrow key
  - EA-EUI-91 = APC/SC
  - EA-EUI-95 = APC/E-2000
- Example: PPM-352B-EG-ER-EA-EUI-91

**Rugged Handheld Solutions**

- OPTICAL**
  - OTDRs
  - OLTs
  - Power meters
  - Light sources
  - Talk sets
- COPPER ACCESS**
  - ADSL/ADSL2+, SHDSL, VDSL test sets
  - VoIP and IPTV test sets
  - Ethernet test sets
  - POTS test sets

**Platform-Based Solutions**

- OPTICAL FIBER**
  - OTDRs
  - OLTs
  - ORL meters
  - Variable attenuators
- DWDM TEST SYSTEMS**
  - OSAs
  - PMD analyzers
  - Chromatic dispersion analyzer
- TRANSPORT AND DATACOM**
  - Next-generation SONET/SDH and OTN testers
  - SONET/DSn (DS0 to OC-192) testers
  - SDH/PDH (64 kbit/s to STM-64) testers
  - T1/T3, E1 testers
  - 10/100 Mbit/s and Gigabit Ethernet testers
  - Fibre Channel testers
  - 10 Gigabit Ethernet testers

EXFO Corporate Headquarters > 400 Godin Avenue, Quebec City (Quebec) G1M 2K2 CANADA | Tel.: 1 418 683-0211 | Fax: 1 418 683-2170 | info@EXFO.com

Toll-free: 1 800 663-3936 (USA and Canada) | www.EXFO.com

<b>EXFO America</b>	3701 Plano Parkway, Suite 160	Plano, TX 75075 USA	Tel: 1 800 663-3936	Fax: 1 972 836-0164
<b>EXFO Europe</b>	Omega Enterprise Park, Electron Way	Chandlers Ford, Hampshire S053 4SE ENGLAND	Tel: +44 2380 246810	Fax: +44 2380 246801
<b>EXFO Asia</b>	151 Chin Swee Road, #03-29 Manhattan House	SINGAPORE 169876	Tel: +65 6333 8241	Fax: +65 6333 8242
<b>EXFO China</b>	No. 88 Fuhua, First Road, Central Tower, Room 801 Futian District	Shenzhen 518048, CHINA	Tel: +86 (755) 8203 2300	Fax: +86 (755) 8203 2306
	Beijing New Century Hotel Office Tower, Room 1754-1755 No. 6 Southern Capital Gym Road	Beijing 100044 P.R. CHINA	Tel: +86 (10) 6849 2738	Fax: +86 (10) 6849 2662

EXFO is certified ISO 9001 and attests to the quality of these products. This device complies with Part 15 of the FCC Rules. Operation is subject to the following two conditions: (1) this device may not cause harmful interference, and (2) this device must accept any interference received, including interference that may cause undesired operation. EXFO has made every effort to ensure that the information contained in this specification sheet is accurate. All of EXFO's manufactured products are compliant with the European Union's WEEE directive. For more information, please visit [www.EXFO.com/recycle](http://www.EXFO.com/recycle). However, we accept no responsibility for any errors or omissions, and we reserve the right to modify design, characteristics and products at any time without obligation. Units of measurement in this document conform to SI standards and practices. Contact EXFO for prices and availability or to obtain the phone number of your local EXFO distributor.

For the most recent version of this spec sheet, please go to the EXFO website at <http://www.EXFO.com/specs>

In case of discrepancy over any printed literature.

SPPPM-350B.BAN

© 2007 EXFO Electro-Optical Engineering Inc. All rights reserved.



Printed in Canada 07/11



EXPERTISE REACHING OUT

überreicht durch:  
**Opternus**

Opternus GmbH Optische Spleiss- & Messtechnik

Bahnhofstr. 5  
D-22941 Bargteheide  
Tel. +49(0)4532-20 44-0  
Fax +49(0)4532-20 44-25

E-Mail: [Info@Opternus.de](mailto:Info@Opternus.de) - [www.Opternus.de](http://www.Opternus.de)

Büro Süd:

Wäldenbronner Str. 2  
D-73732 Esslingen  
Tel. +49(0)711-3 10 59 99-0  
Fax +49(0)711-3 10 59 99-99

Opternus GmbH  
März 2008