

ETS-1000L

NETWORK TESTING—TRANSPORT AND DATACOM



Cost-effective loopback tool for easy Ethernet services testing

- 10/100/1000BaseT and GigE ports
- Can be used as a remote loopback/reflector for all carrier Ethernet validation tests including RFC 2544, bit-error rate (BER) and quality of service (QoS)
- Selectable loopback at layers 1 through 4
- Complete interoperability with EXFO's Ethernet analyzers (ETS-1000, AXS-200/850 series, RTU-310/310G) and Ethernet test modules (FTB-8510B, FTB-8510G, FTB-8525/8535 and FTB-8120NGE/8130NGE)
- 802.3ah remote loopback support

Next-Generation Network Assessment



überreicht durch:

Opternus

Opternus GmbH Optische Spleiss- & Messtechnik

Bahnhofstr. 5
D-22941 Bargteheide

Tel. +49(0)4532-20 44-0
Fax +49(0)4532-20 44-25

E-Mail: Info@Opternus.de - www.Opternus.de

Büro Süd:

Wäldenbronner Str. 2
D-73732 Esslingen

Tel. +49(0)711-3 10 59 99-0
Fax +49(0)711-3 10 59 99-99

Field Assessment of Carrier Ethernet Services

EXFO's ETS-1000L is a cost-effective, compact Ethernet loopback tool that can be used as a remote unit to return test traffic, enabling service providers to turn-up and install next-generation carrier Ethernet services. It is fully compatible with EXFO's complete portfolio of Ethernet analyzers (ETS-1000, AXS-850 series, RTU-310/310G) and Ethernet test modules (FTB-8510B, FTB-8510G, FTB-8525/8535 and FTB-8120NGE/8130NGE).

The ETS-1000L supports the following interfaces: 10/100/1000Base-T, 1000Base-SX, 1000Base-LX and 1000Base-ZX. Thanks to this simple loopback tool, technicians can loop back traffic up to layer 4 with configurable MAC, IP and VLAN parameters. The ETS-1000L can also be used as an endpoint for all of today's necessary Ethernet/IP field testing applications including RFC 2544, bit-error-rate testing, packet jitter as well as multistream generation and analysis (quality of service testing).

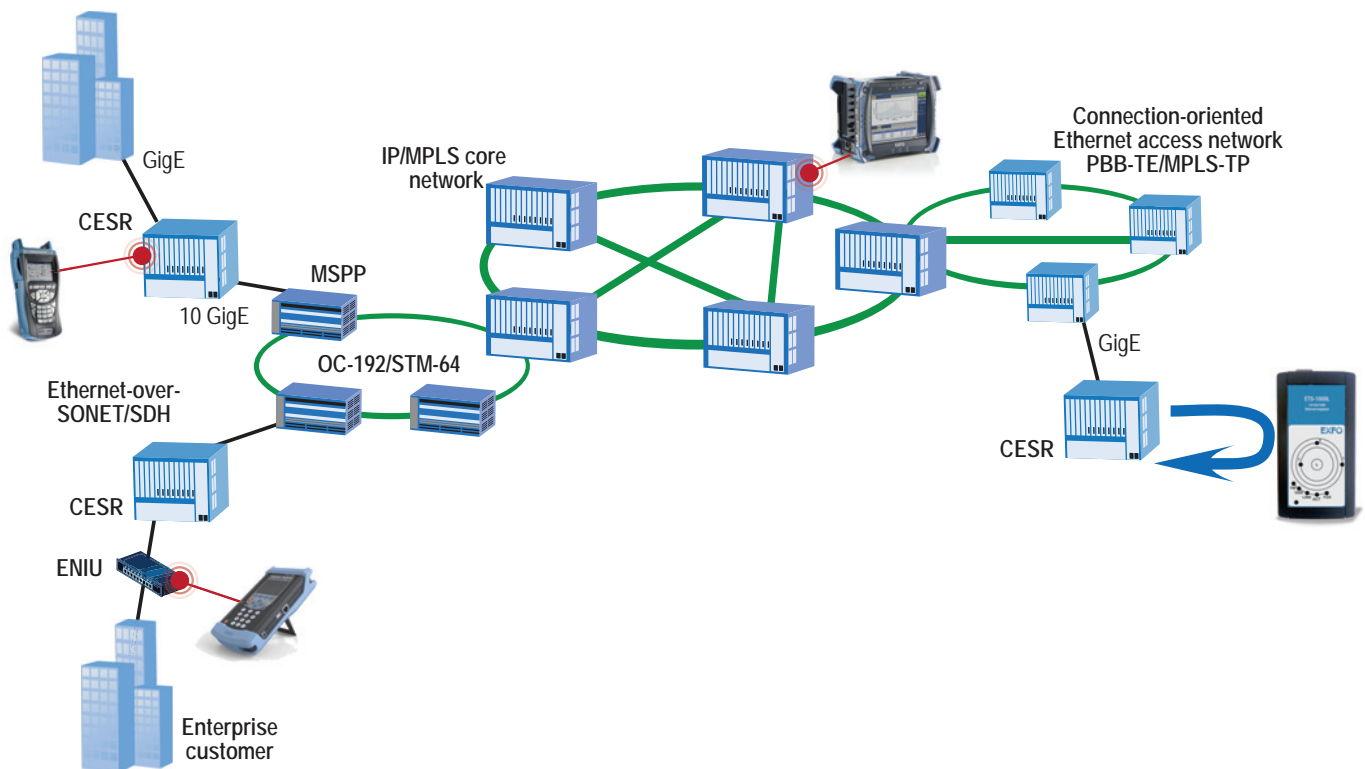

Key Features

- 10/100/1000BaseT and GigE ports
- Can be used as a remote loopback/reflector for all carrier Ethernet validation tests including RFC 2544, bit-error rate and quality of service (QoS)
- Supports user-configurable full line rate loopback at layers 1 through 4
- 802.3ah remote loopback support
- Complete interoperability with EXFO's Ethernet analyzers (ETS-1000, AXS-200/850 series, RTU-310/310G) and Ethernet test modules (FTB-8510B, FTB-8510G, FTB-8525/8535 and FTB-8120NGE/8130NGE)
- Responds to ping requests
- Configurable MAC/IP address and VLAN

Specifications

OPTICAL INTERFACES

Optical interfaces			
Available wavelengths (nm)			
	1000Base-SX	1000Base-LX	1000Base-ZX
Wavelength (nm)	850	1310	1550
Transmission level (dBm)	-9 to -3	-9.5 to -3	0 to +5
Reception level sensitivity (dBm)	-20	-22	-22
Maximum reach	550 m	10 km	80 km
Transmission bit rate (Gbit/s)	1.25	1.25	1.25
Reception bit rate (Gbit/s)	1.25	1.25	1.25
Transmission operational wavelength range (nm)	830 to 860	1270 to 1360	1540 to 1570
Maximum reception before damage (dBm)	+6	+6	+6
Measurement accuracy			
Frequency (ppm)	±4.6	±4.6	±4.6
Optical power (dB)	±2	±2	±2
Jitter compliance	IEEE 802.3	IEEE 802.3	
Ethernet classification	IEEE 802.3	IEEE 802.3	
Laser type	VCSEL	FP	DFB
Eye safety	Class 1	Class 1	Class 1
Connector	LC	LC	LC
Transceiver type	SFP	SFP	SFP

ELECTRICAL INTERFACES

Electrical interfaces			
Two ports 10/100BaseT half/full duplex, 1000BaseT full duplex			
Straight/crossover cable auto-detection			
Transmission bit rate	10 Mbit/s	125 Mbit/s	1 Gbit/s
Transmission accuracy (ppm)	±100	±100	±100
Reception bit rate	10 Mbit/s	125 Mbit/s	1 Gbit/s
Reception measurement accuracy (ppm)	±4.6	±4.6	±4.6
Duplex mode	Half and full duplex	Half and full duplex	Full duplex
Jitter compliance	IEEE 802.3	IEEE 802.3	IEEE 802.3
Connector	RJ-45	RJ-45	RJ-45
Maximum reach (m)	100	100	100

Ethernet Functional Specifications

TESTING

Loopback 802.3ah (OAM)	Capability to return traffic to the local unit by swapping packet overhead up to layer 4 of the OSI stack; user-selectable. Supports 802.3ah Ethernet-in-the-First-Mile OAM passive mode, allowing remote test equipment to initiate a loopback on the ETS-1000L.
Configurable address	Capability to configure the MAC,IP addresses and VLAN ID of the test port.
Remote control	Remote control of the unit via test port.

GENERAL SPECIFICATIONS

Size (H x W x D)	125 mm x 68 mm x 30 mm
Weight	0.135 kg
Temperature	
operating	0 °C to 45 °C
storing	-40 °C to 60 °C
Relative Humidity	0 % to 93 %, non-condensing
Power consumption	12 W
Languages	English, Spanish, Chinese

ORDERING INFORMATION

ETS-1000L

Example: ETS-1000L

EXFO Corporate Headquarters > 400 Godin Avenue, Quebec City (Quebec) G1M 2K2 CANADA | Tel.: +1 418 683-0211 | Fax: +1 418 683-2170 | info@EXFO.com

Toll-free: +1 800 663-3936 (USA and Canada) | www.EXFO.com

EXFO America	3701 Plano Parkway, Suite 160	Plano, TX 75075 USA	Tel.: +1 800 663-3936	Fax: +1 972 836-0164
EXFO Asia	151 Chin Swee Road, #03-29 Manhattan House	SINGAPORE 169876	Tel.: +65 6333 8241	Fax: +65 6333 8242
EXFO China	Beijing New Century Hotel Office Tower, Room 1754-1755 No. 6 Southern Capital Gym Road	Beijing 100044 P. R. CHINA	Tel.: +86 (10) 6849 2738	Fax: +86 (10) 6849 2662
EXFO Europe	Omega Enterprise Park, Electron Way	Chandlers Ford, Hampshire S053 4SE ENGLAND	Tel.: +44 2380 246810	Fax: +44 2380 246801
EXFO Service Assurance	285 Mill Road	Chelmsford, MA 01824 USA	Tel.: +1 978 367-5600	Fax: +1 978 367-5700

EXFO is certified ISO 9001 and attests to the quality of these products. This device complies with Part 15 of the FCC Rules. Operation is subject to the following two conditions: (1) this device may not cause harmful interference, and (2) this device must accept any interference received, including interference that may cause undesired operation. EXFO has made every effort to ensure that the information contained in this specification sheet is accurate. However, we accept no responsibility for any errors or omissions, and we reserve the right to modify design, characteristics and products at any time without obligation. Units of measurement in this document conform to SI standards and practices. In addition, all of EXFO's manufactured products are compliant with the European Union's WEEE directive. For more information, please visit www.EXFO.com/recycle. Contact EXFO for prices and availability or to obtain the phone number of your local EXFO distributor.

For the most recent version of this spec sheet, please go to the EXFO website at <http://www.EXFO.com/specs>

In case of discrepancy, the Web version takes precedence over any printed literature.

SPETS1000L.1AN

© 2009 EXFO Electro-Optical Engineering Inc. All rights reserved.



Printed in Canada 09/12



überreicht durch:



Opternus GmbH Optische Spleiss- & Messtechnik

Bahnhofstr. 5
D-22941 Bargtheide
Tel. +49(0)4532-20 44-0
Fax +49(0)4532-20 44-25

Büro Süd:

Wäldenbronner Str. 2
D-73732 Esslingen
Tel. +49(0)711-3 10 59 99-0
Fax +49(0)711-3 10 59 99-99

E-Mail: Info@Opternus.de - www.Opternus.de